

RECOMMEND PCB LAYOUT
GENERAL TOLORANCE ±0.05

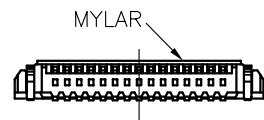
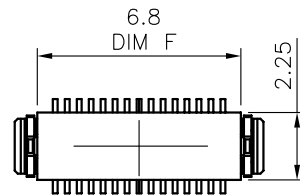
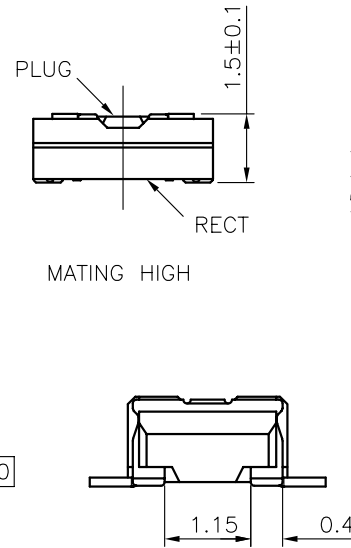
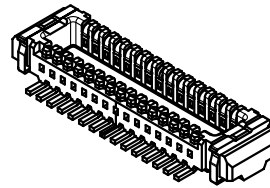

NOTES:

1. MATERIAL:

1.1 HOUSING: THERMOPLASTIC, HIGH TEMP
UL94V-0; COLOR: BLACK

1.2 CONTACT: COPPER ALLOY

1.3 FITTING : COPPER ALLOY

2. FINISH

2.1 CONTACT:

50u" MIN. NICKEL UNDERPLATING OVERALL
1: GOLD FLASH PLATING OVERALL

2.2 SOLDER

50u" MIN. NICKEL UNDERPLATING OVERALL
1: GOLD FLASH PLATING OVERALL

2.3 FITTING NAIL:

50u" MIN. NICKEL UNDERPLATING OVERALL
N: 100u" MIN, MATT TIN UNDERPLATING OVERALL

3. REFLOW SOLDER CAPABLE TO 260°C
PER ACES SPEC.

4. SPEC. PLS. REFER TO PS-51150-XXXX-XXX

5. PACKAGE PLS. REFER TO 51150-XXXX-00-TRP

6. MATING CONNECTOR P/N 51151-XXXX-XXX

7. PART NUMBER

51150-XXX X X -XXX

CKTS _____ 001-WITHOUT BOST

PACKAGE _____ CONTACT PLATED
4. TAPE & REEL WITH MYLAR 1. GOLD FLASH ON CONTACT

30	8.30	5.60	7.25	6.50	5.20	6.80
CKT	DIM A	DIM B	DIM C	DIM D	DIM E	DIM F

一般公差 TOLERANCES X ±0.50 .XX ±0.15 X ±0.25 .XXX ±0.10 ANGLES ±2°		宏致電子股份有限公司 Aces Electronics Co.,Ltd.	
檢驗尺寸標示 SYMBOLS (M) (D) INDICATE CLASSIFICATION DIMENSION (M) MARK IS CRITICAL DIM. (D) MARK IS MAJOR DIM.	品名 (TITLE) 0.4 BTB PLUG CONN.	製圖 (DR) '16/12/06 審核 (CHKD) BRAVE	核准 (APPD) FRANK
表面處理 (FINISH) _____	圖號 (DWG.NO) 51150-xxxx-xxx	比例 (SCALE) 單位 (UNITS) 10:1 mm	張數 (SHEET) 1 OF 1 尺寸 (SIZE) A4 版次 (REV) A